

8 7 6 5 4 3 2 1

REVISIONS			
REV.	DESCRIPTION	DATE	APPROVED

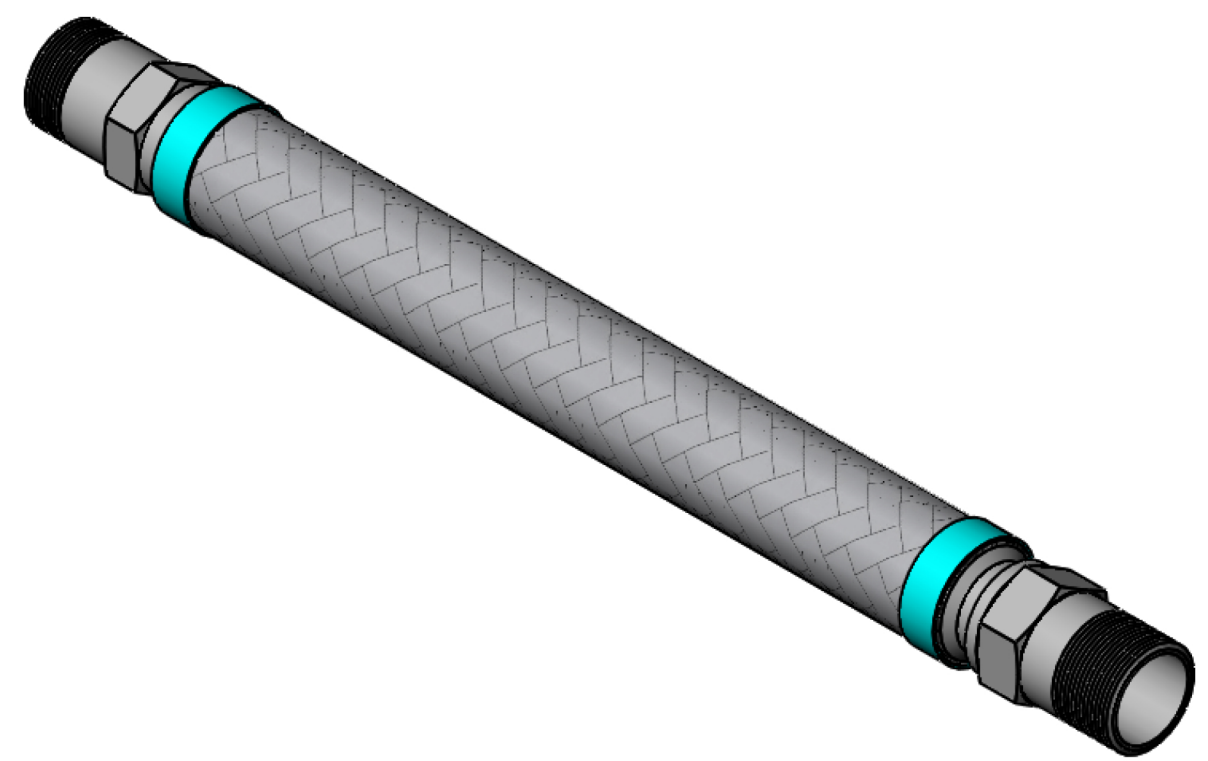

ITEM #	QTY.	PART NUMBER	DESCRIPTION	MATERIAL	WEIGHT
1	1	HOSE	300 Series Stainless HYDROFORMED Corrugated Hose	Stainless Steel	0.74
2	1	BRAID	300 Series Stainless Steel	Stainless Steel	0.07
3	2	BRAID COLLAR	0.05" Thick	Stainless Steel	0.07
4	1	1.5" MALE	1.5" Male, 1-1/2"x11-1/2" Thread, 1.94" Hex	Carbon Steel	1.13
5	1	1.5" MALE SWIVEL	1.5" Male Swivel, 1-1/2"x11-1/2" Thread, 1.94" Hex	Carbon Steel	1.40

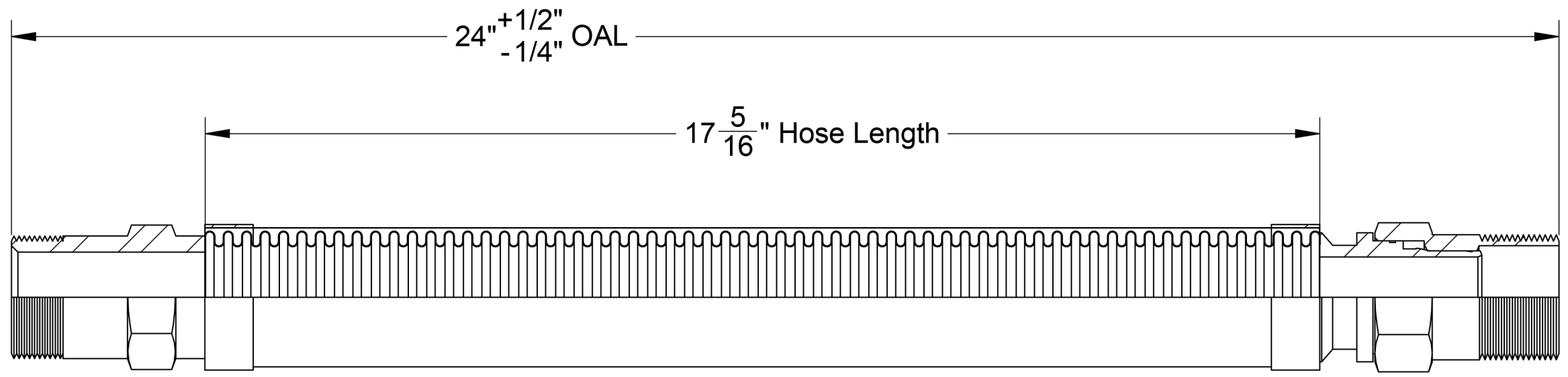

**HOSE MASTER Inc.**

1233 East 222nd Street • Cleveland, Ohio 44117  
 (800) 221-2319 • Fax: (216) 481-7557 • www.hosemaster.com  
 Locations: **Cleveland • Houston**

Registered to:  
ISO 9001 : 2000

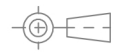

NAHAD  
Listed Manufacturer

Projection:	Customer: Hose Master Inc.	Prepared By: <b>kannk</b>	
	Reference: Fire-Shield - 1.5" Male x 1.5" Male Swivel x 24" OAL	CALC. WEIGHT: <b>3 lbs.</b>	Date: <b>9/24/2009</b>
Description:	<b>1.5" ID x 24" OAL 300 Series Stainless HYDROFORMED Corrugated Hose covered by 300 Series Stainless Braid. UL Approved 1.5" Male Connector x 1.5" Male Swivel Connector</b>		
	Drawing #:	<b>FSMS0150x24</b>	Rev.: - SHEET 1 OF 1

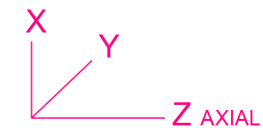

8 7 6 5 4 3 2 1